

Product Information



4681ITP125P63 SH80

EAN 4031582337624

Swivel caster with directional lock, housing made of very heavy pressed steel, reinforced, bright zinc plated, blue passivated, sealed swivel double ball bearing, reinforced and heat-treated ball covers, riveted king pin, wheel axle with nut. Wheel center made of Aluminum, Tread: Polyurethane, casted, precision ball bearing, plate fitting

Hint: This caster can be fitted with a directional lock. However, the lock does not come as standard and has to be ordered as an added option.



Technical Data

Wheel diameter	125 mm
Tread width	50 mm
Plate size	140 x 110 mm
Plate hole centers	105 x 80/74 mm
Plate hole	11 mm
Offset	55 mm
Swivel Interference	360 mm
Overall height	164 mm
Temperature	- 20 / + 60 °C
Standard	EN 12532
Load capacity (dynamic)	400 kg
Load capacity (static)	800 kg
Hardness of tread	A 80 Shore

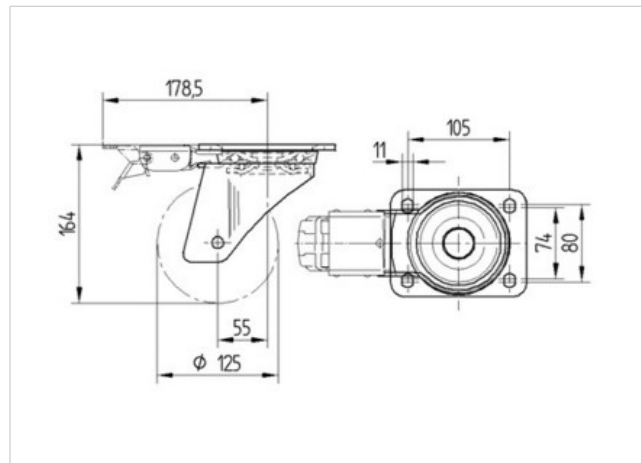

Roll performance	+	+	+	+	+
Movement noise	+	+	+	+	+
Attrition	+	+	+	+	+
Corrosion resistance	+	+	+	+	+

Product Information



4681ITP125P63 SH80

EAN 4031582337624

