

Product Information



LINEA

5944UAP150R36-32S300H155

EAN 4031582338904

Swivel Caster with central, total or directional lock, housing made of Polyamide, precision ball bearing in swivel head. Wheel center made of Polyamide, Tread: Polyurethane, precision ball bearing, stem with cam hole for profile bars, short version

Hint:TÜV Süd certified product.

Technical Data

Wheel diameter	150 mm
Tread width	15 mm
Caster width	71 mm
Bolt-Ø	32 mm
Bolt length	50 mm
Offset	47.5 mm
Swivel Interference	245 mm
Overall height	155 mm
Temperature	- 10 / + 40 °C
Standard	EN 12531
Weight	1.11 kg
Load capacity (dynamic)	150 kg
Load capacity (static)	300 kg
Swivel Radius	122.5 mm

Roll performance	+	+	+	+	+
Movement noise	+	+	+	+	+
Attrition	+	+	+	+	+
Corrosion resistance	+	+	+	+	+

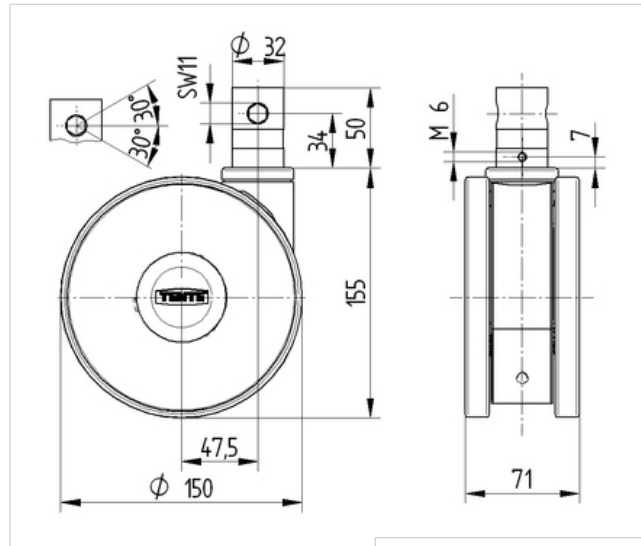

Product Information



LINEA

5944UAP150R36-32S30OH155

EAN 4031582338904

