

Product Information



LINEA

5941UAP100P30-11 RAL9002

EAN 4031582368697

Swivel caster with directional lock, housing made of Polyamide, precision ball bearing in swivel head.

Wheel center made of Polyamide, Tread: Polyurethane, precision ball bearing, bolt hole

Technical Data

Wheel diameter	100 mm
Tread width	20 mm
Caster width	82 mm
Center hole	11 mm
Dome-Ø	52 mm
Offset	32 mm
Swivel Interference	180 mm
Overall height	119 mm
Temperature	- 10 / + 40 °C
Standard	EN 12530
Weight	0.749 kg
Load capacity (dynamic)	100 kg
Load capacity (static)	200 kg
Hardness of tread	A 92 Shore

Roll performance	+	+	+	+	+
Movement noise	+	+	+	+	+
Attrition	+	+	+	+	+
Corrosion resistance	+	+	+	+	+

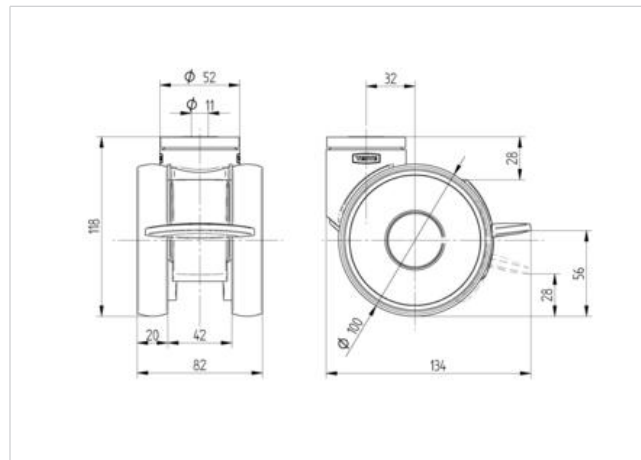

Product Information



LINEA

5941UAP100P30-11 RAL9002

EAN 4031582368697

