

Product Information



2875ZIP125P30-13 RIGHT

EAN 4031582324372

Walkway caster with automatic side brake for moving walkways, flanged wheel with one ball race, left and right hand design, housing made of pressed steel, bright zinc plated, blue passivated, double ball bearing swivel head, wheel axle with nut, Wheel center: plastic, Tread: rubber, with threadguards, precision ball bearing. Designed for the following pallet size: track width: approx. 2,75 mm, groove width: approx. 5,7 mm, groove depth: > 10 mm. **Hint:** Load capacity 100 kg per caster on level and securely attached floors, 40 kg per caster on walkways. Use on uneven floors, outdoors (ground beams, gaps, joints, manhole covers, etc.) can affect the life expectancy of casters. Load capacity 80 kg per caster on level and securely attached floors, 40 kg per caster on walkways. Please note that according to EN1929 only casters with a minimum wheel diameter of 120 mm can be used on walkways.

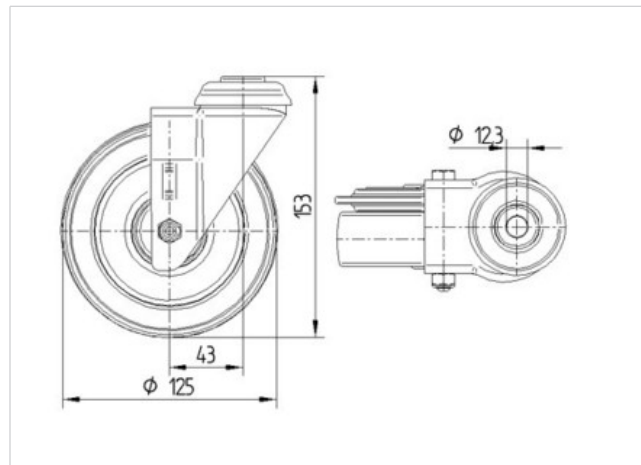

Technical Data

Wheel diameter	125 mm
Tread width	32 mm
Center hole	13 mm
Offset	40 mm
Swivel Interference	123 mm
Overall height	153 mm
Temperature	- 20 / + 60 °C
Standard	EN 12530
Weight	0.936 kg
Load capacity (dynamic)	100 kg
Load capacity (static)	200 kg
Hardness of tread	D 80 Shore

Roll performance	+	+	+	+	+
Movement noise	+	+	+	+	+
Attrition	+	+	+	+	+
Corrosion resistance	+	+	+	+	+

Product Information



2875ZIP125P30-13 RIGHT

EAN 4031582324372

